

GYHFR

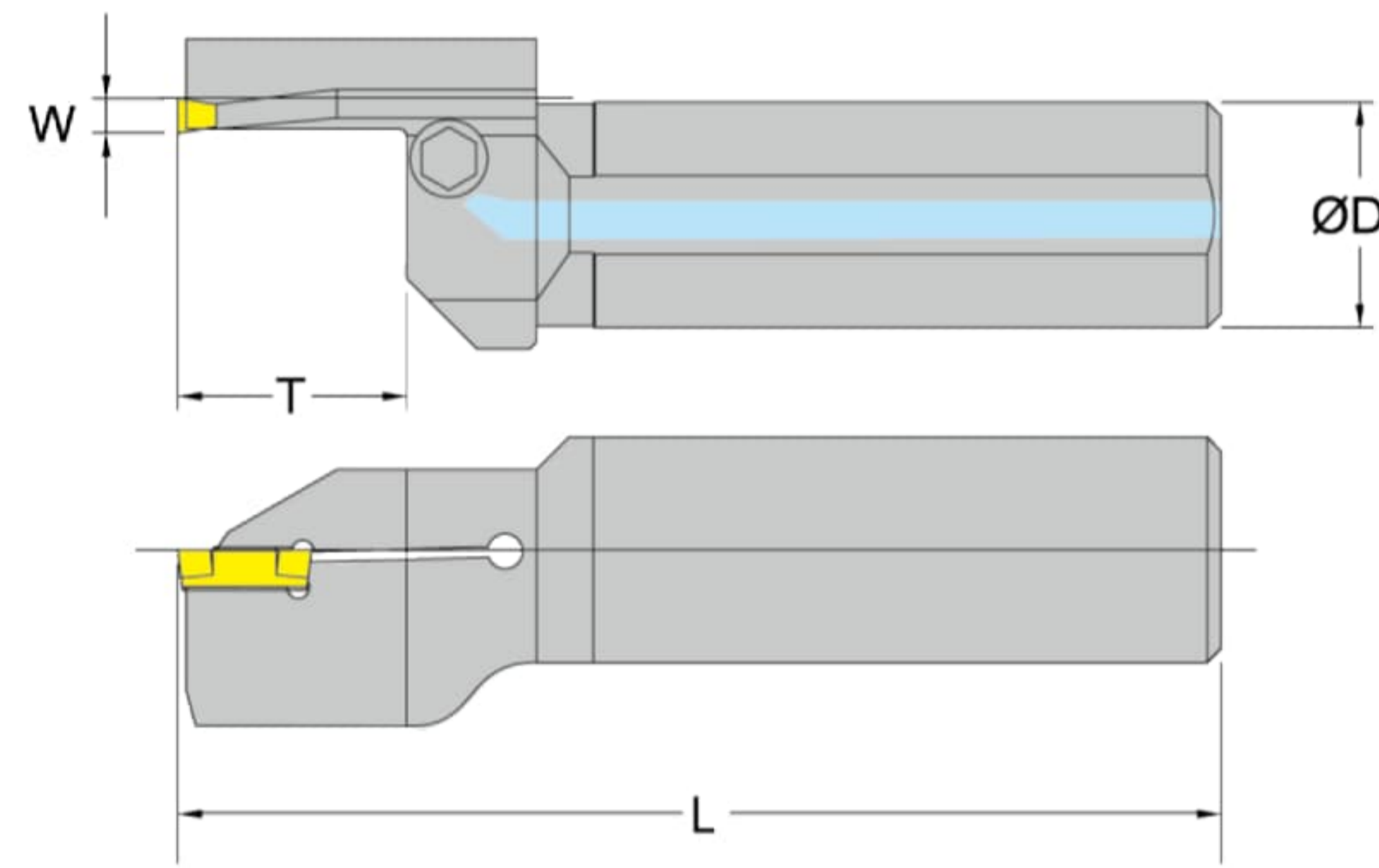
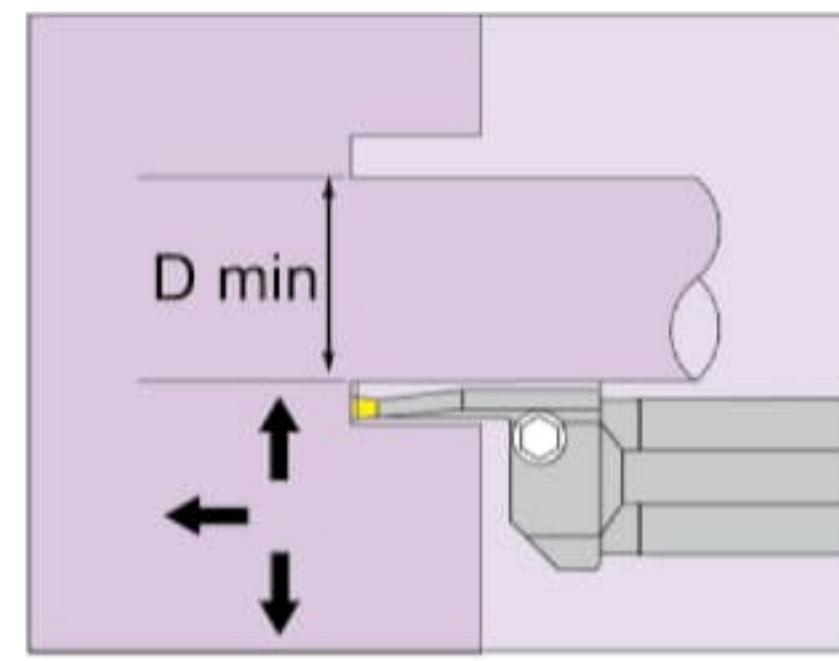

■ Right hand tool holder shown.(For Mitsubish Insert)

Order number	Insert number	Dimensions (mm)					Screw	Wrench
		ØD	L	T	W	Dmin		
COOLANT 中心出水	A25M GYHFR 29-34 2T06	GY2M 0200F020N GS/GM/GFGS/MS (0239E/0250E)R/L05-GM	25	150	6	2	BX0620	LH-050
	34-44 2T06							
	44-54 2T06							
	54-70 2T12							
	A32M GYHFR 70-100 2T12		32	150	12	2		
	100-150 2T12							
	150-250 2T12							
	250-800 2T12							

F

Order number	Insert number	Dimensions (mm)					Screw	Wrench
		ØD	L	T	W	Dmin		
COOLANT 中心出水	A25M GYHFR 27-34 3T12	GY2M 0300F020N GS/GM/GFGS/MS MM/BM/R/L05-GM (0318F)	25	150	12	3	BX0620	LH-050
	34-44 3T12							
	44-54 3T12							
	54-70 3T20							
	A32M GYHFR 70-100 3T20		32	150	20	3		
	100-150 3T20							
	150-250 3T20							
	250-800 3T20							

Order number	Insert number	Dimensions (mm)					Screw	Wrench
		ØD	L	T	W	Dmin		
COOLANT 中心出水	A25M GYHFR 27-34 4T12	GY2M 0400F020N GS/GM/GFGS/MS MM/BM/R/L05-GM (0318F)	25	150	12	4	BX0620	LH-050
	34-44 4T12							
	44-54 4T12							
	54-70 4T20							
	A32M GYHFR 70-100 4T20		32	150	20	4		
	100-150 4T20							
	150-250 4T20							
	250-800 4T20							

FACE GROOVING SYSTEM

PRECISE

PCDFR

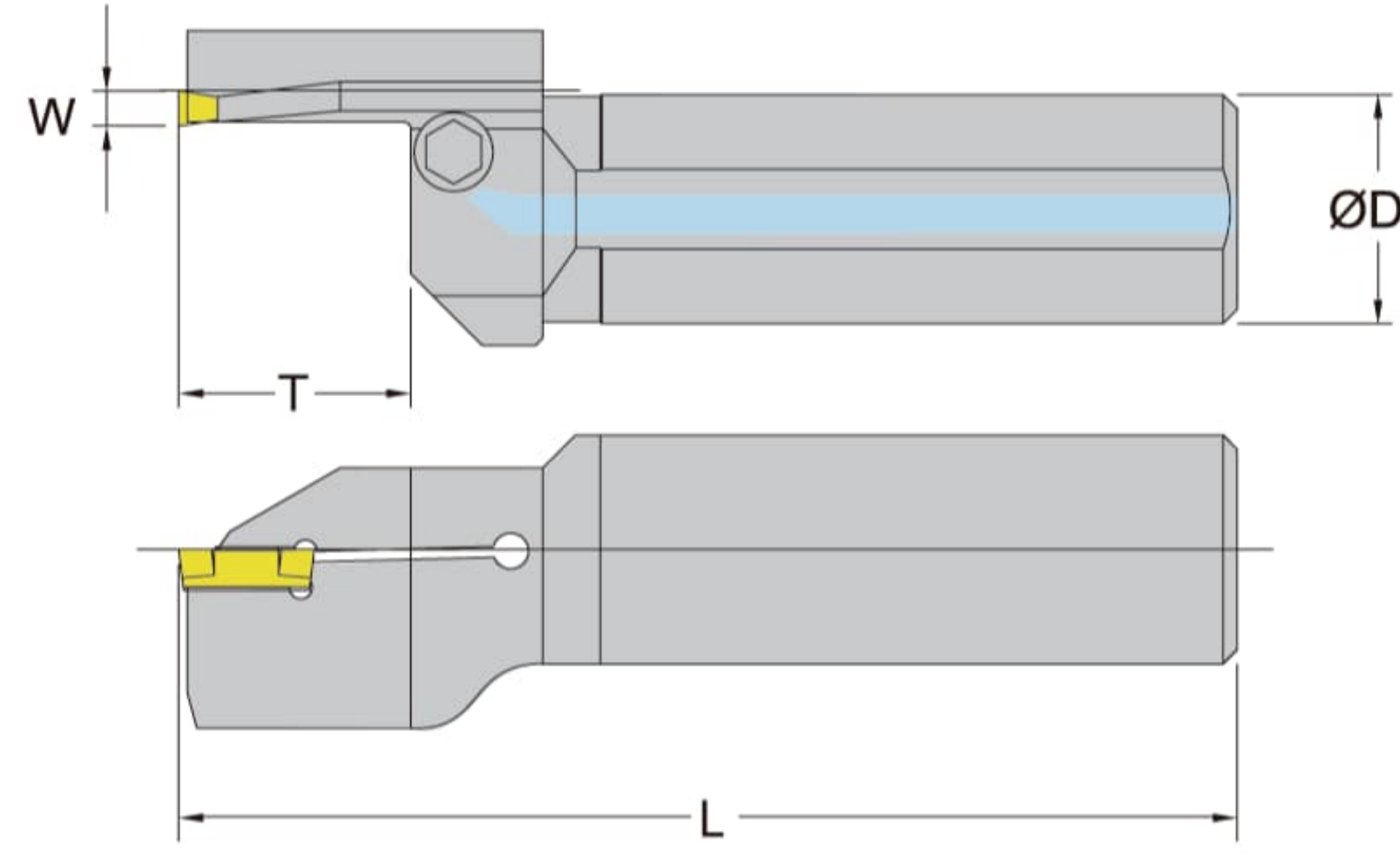
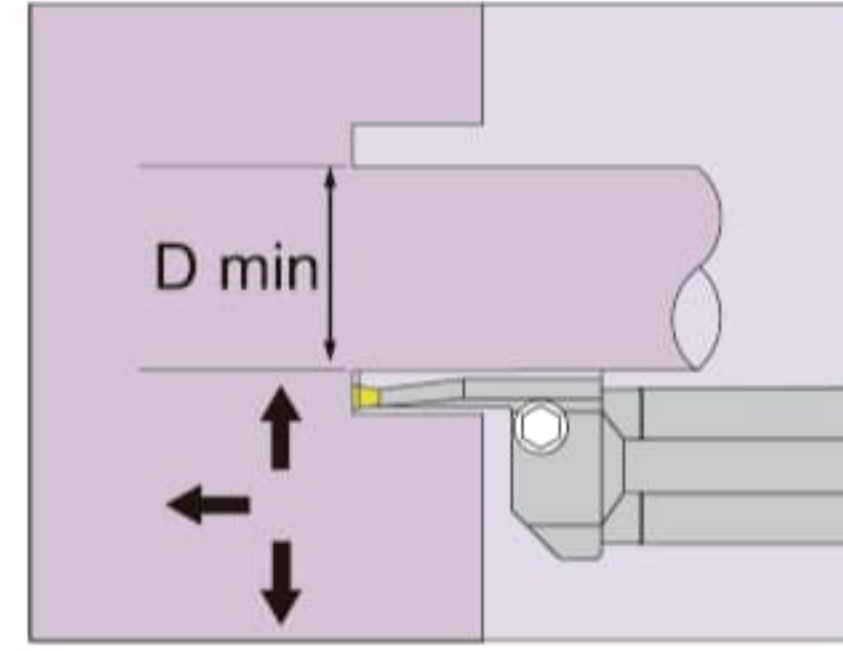

■ Right hand tool holder shown.(For Precise Insert)

	Order number	Insert number	Dimensions (mm)					Screw	Wrench
			ØD	L	T	W	Dmin		
COOLANT 中心出水	A25M PCDFR 29-34 2T06	CD 200R/L/N 250R/L/N (F1/T/M1)	25	150	6	2	29	BX0620	LH-050
	34								
	44								
	54								
	A32M PCDFR 70-100 2T12		32	150	12	2	70		
	100								
	150								
	250								
COOLANT 中心出水	A25M PCDFR 29-34 3T12	CD 300R/L/N (F1/T/M1/R)	25	150	12	3	29	BX0620	LH-050
	34								
	44								
	54								
	A32M PCDFR 70-100 3T20		32	150	20	3	70		
	100								
	150								
	250								
COOLANT 中心出水	A25M PCDFR 29-34 4T12	CD 400/N (F1/T/M1/R)	25	150	12	4	29	BX0620	LH-050
	34								
	44								
	54								
	A32M PCDFR 100-150 4T20		32	150	20	4	70		
	100								
	150								
	250								

F



R



T



M1



F1

F10