

HFHFR/L

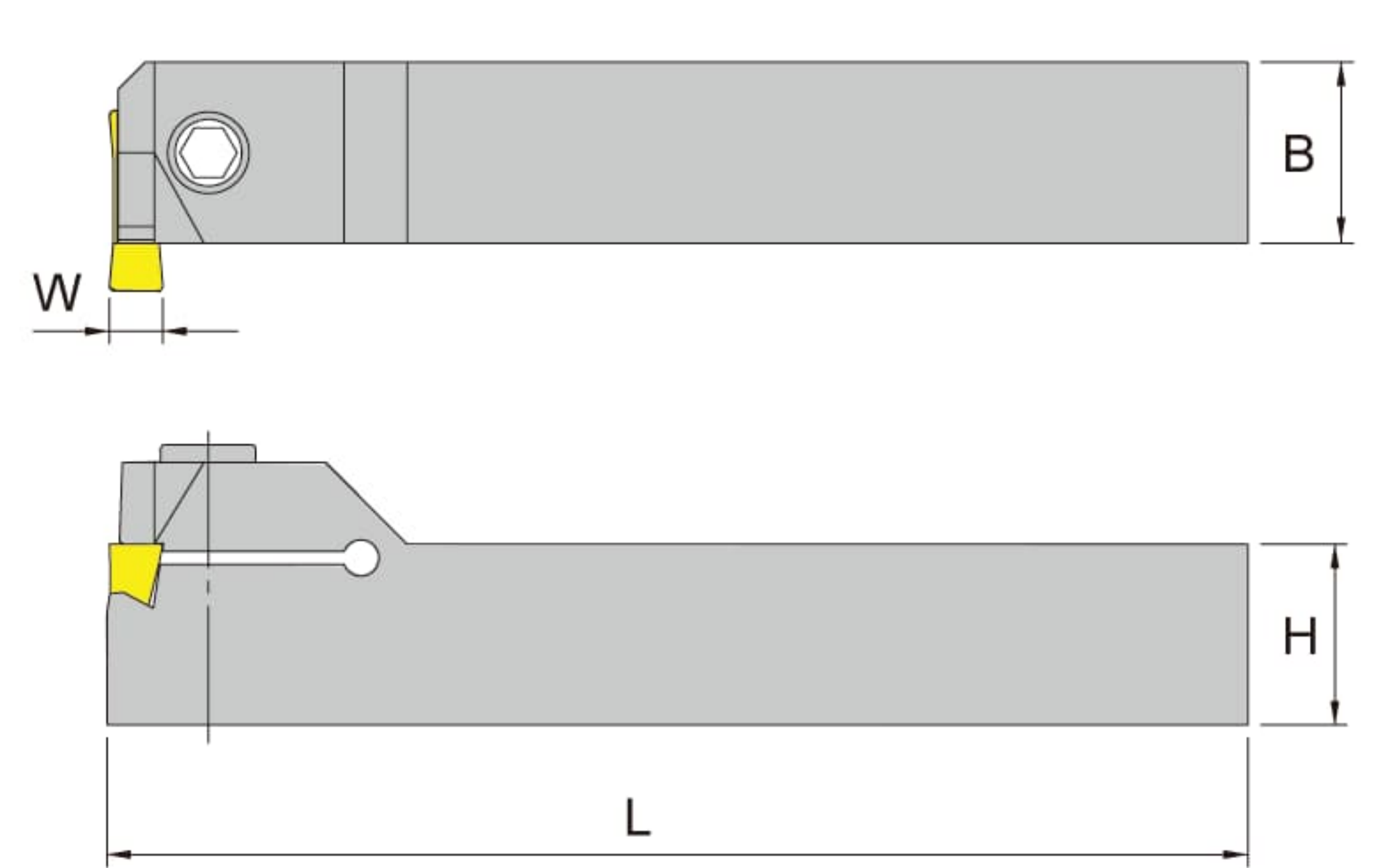
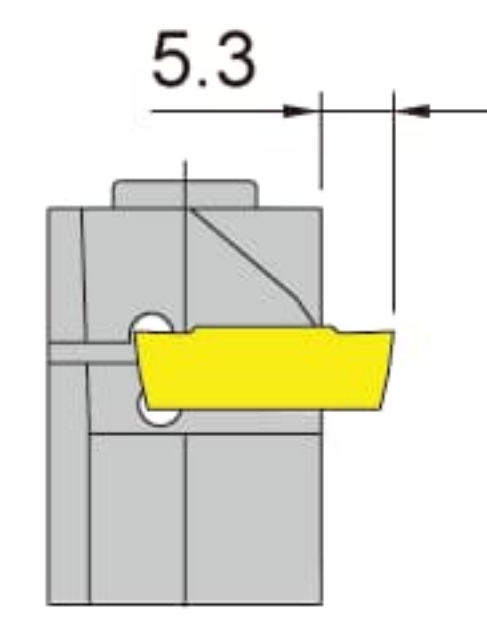
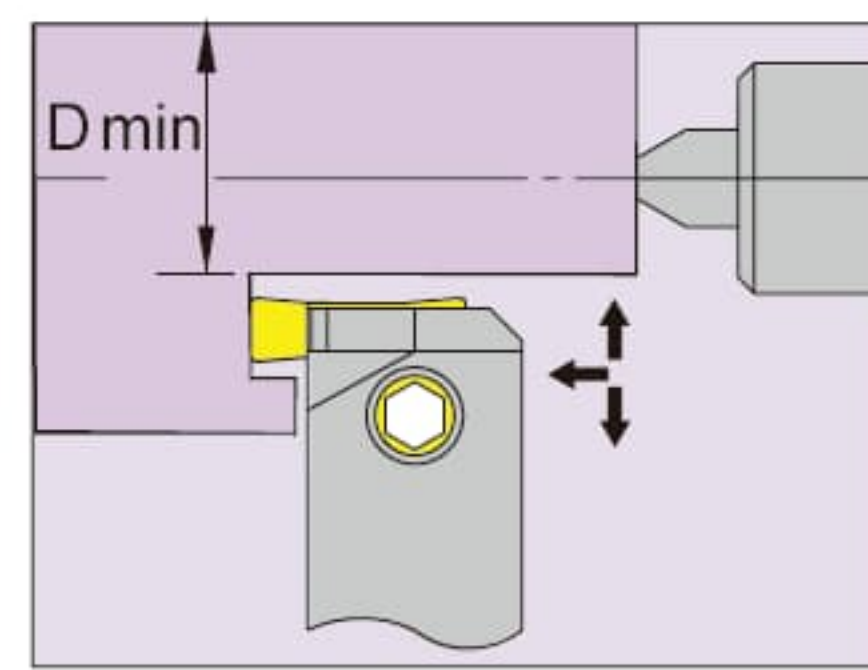
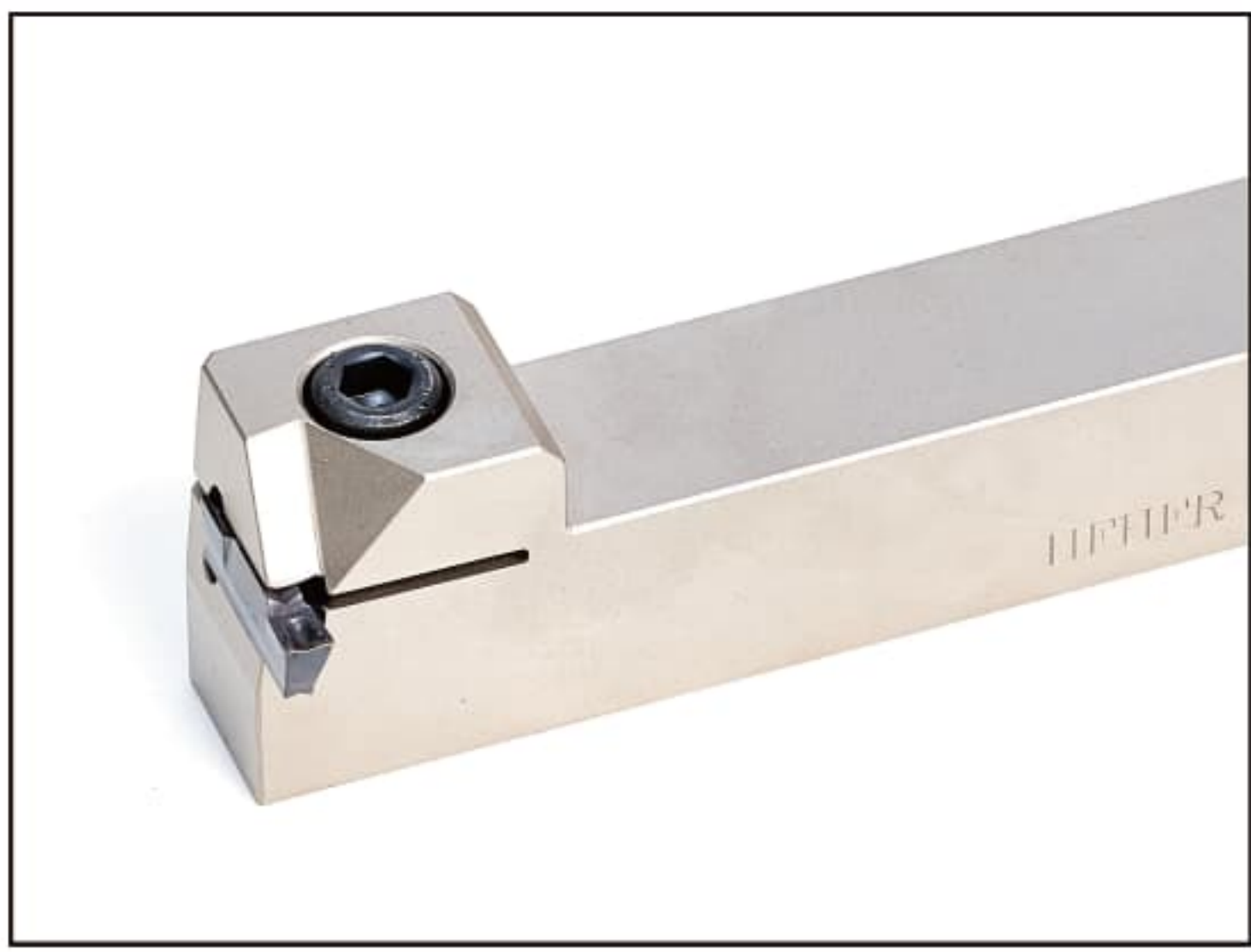

■ Right hand tool holder shown.(For Iscar Insert)

Order number	Insert number	Dimensions (mm)					Screw	Wrench
		H	B	L	W max	D min		
HFHFR/L 2020K	HFPR/L 3003/3015 4004/4020 5004/5025 6004/6030	20	20	125	3-6mm	3=18/54 4=15/82 5=11/290 6=8/∞	BX0620	LH050
2525M		25	25	150				

GHMFR/L

F

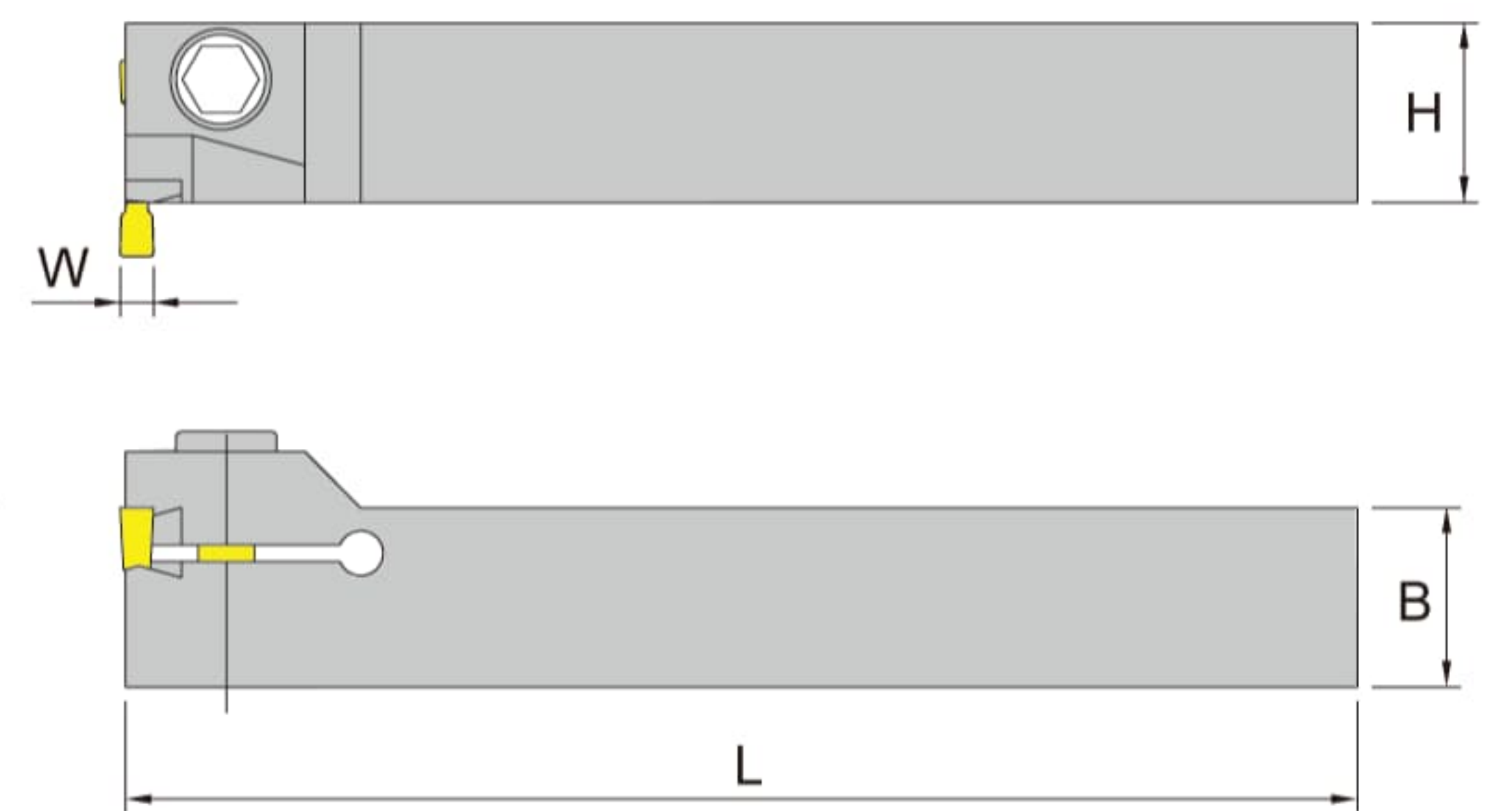
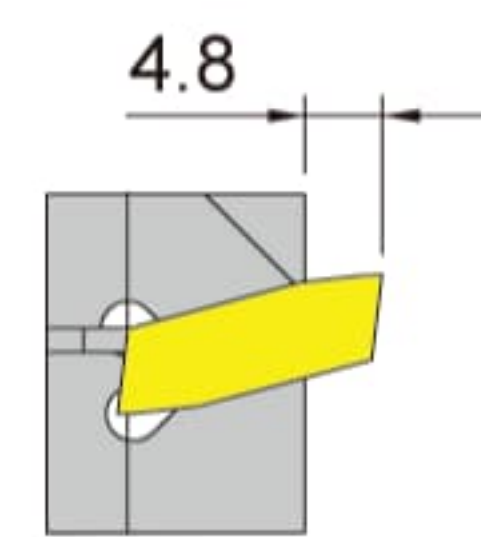
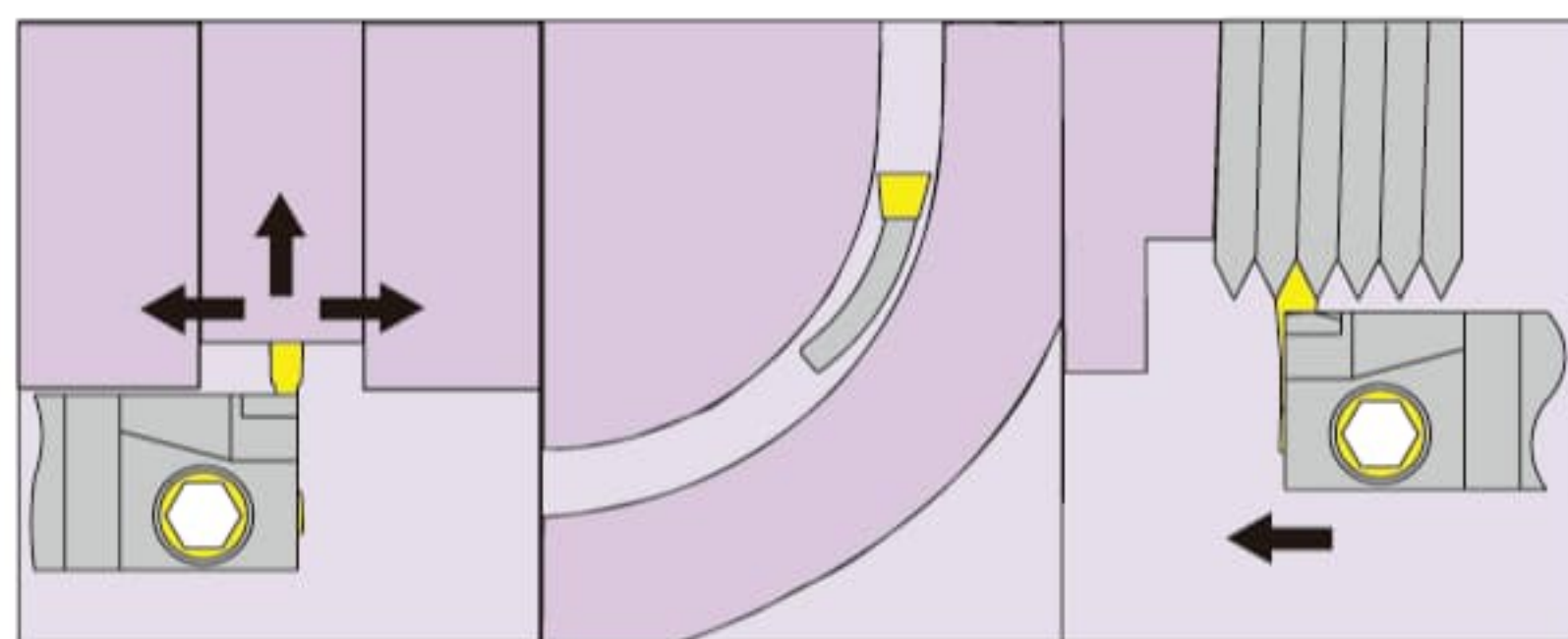

■ Right hand tool holder shown.(For Iscar Insert)

Order number	Insert number	Dimensions (mm)				Screw	Wrench
		H	B	L	W max		
GHMFR/L 1616J-4.8	GIP, GIPM GIF, GIPY TIP, GITM GPV, GIMF GIM, GIM YGIG, GIPA	16	16	110	4.8	BX0516	LH-040
2020K-6.4		20	20	125	6.4		
2525M-6.4		25	25	150			

GHMUR/L

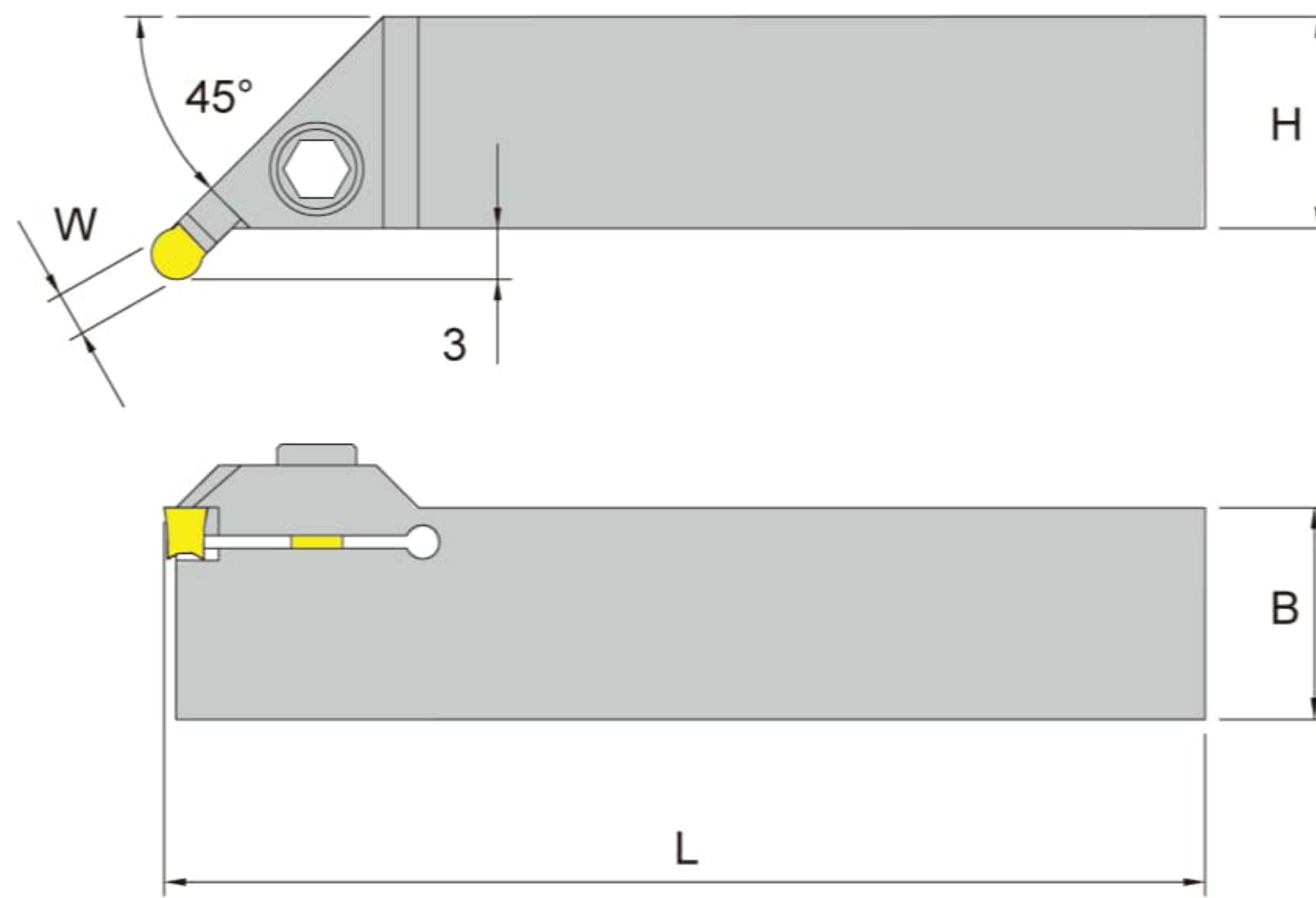
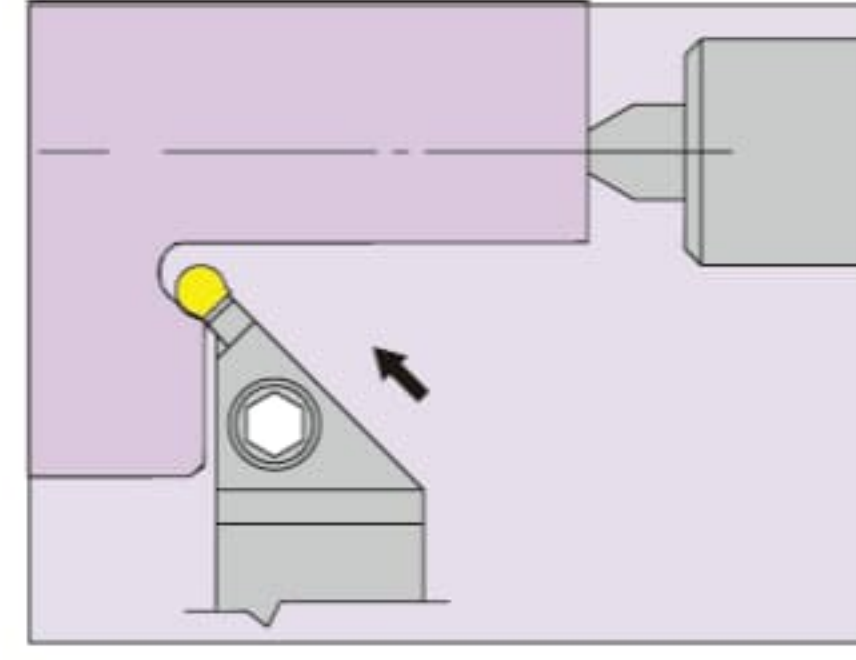
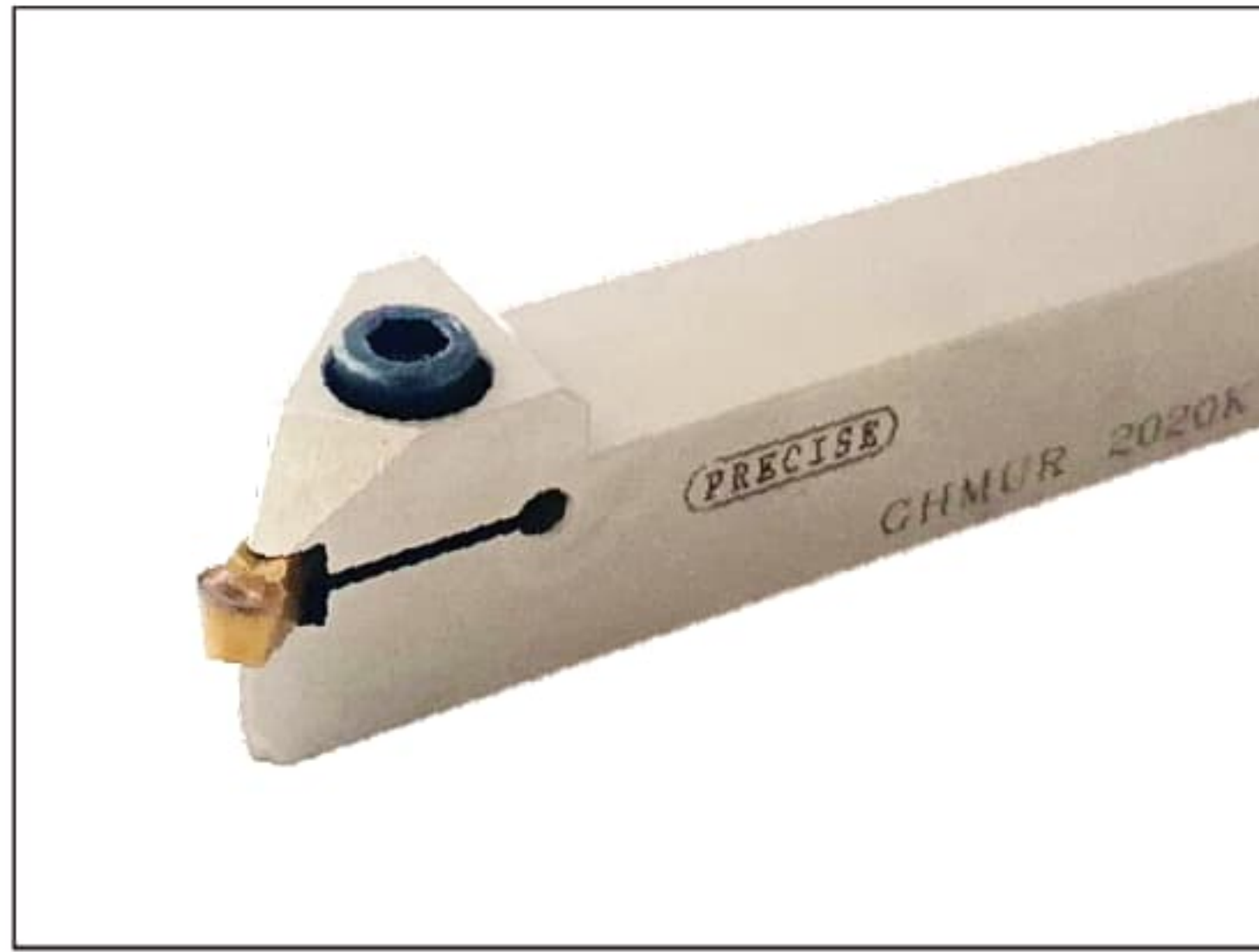

■ Right hand tool holder shown.(For Iscar Insert)

Order number	Insert number	Dimensions (mm)				Screw	Wrench
		H	B	L	W max		
GHMUR/L 1616J	GIP...UM GIMY...UM GIP/GIF...D/G	16	16	110	≤4.8mm	BX0620	LH-050
2020K		20	20	125			
2525M		25	25	150	≤6.4mm		

KGMMR/L

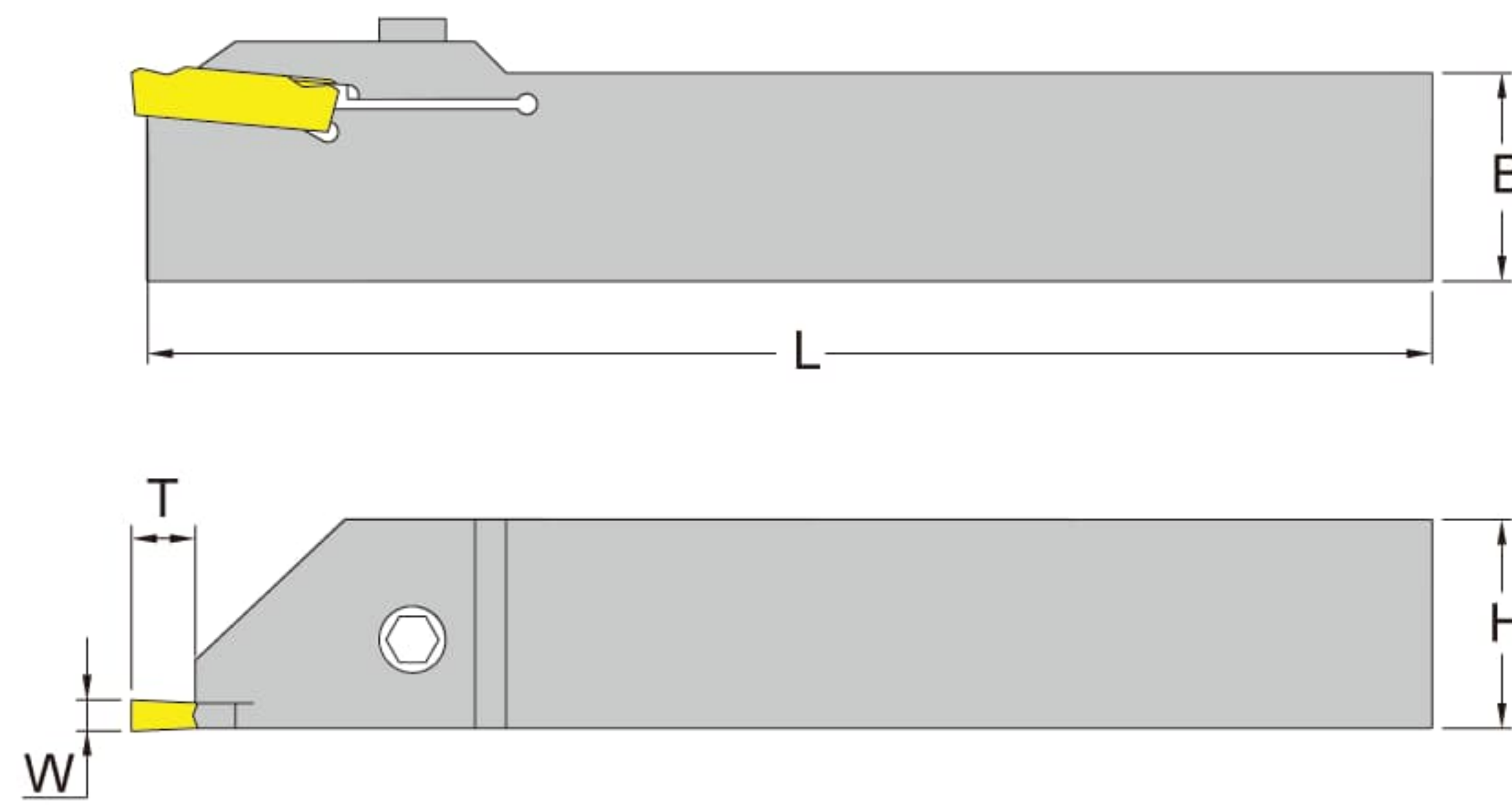
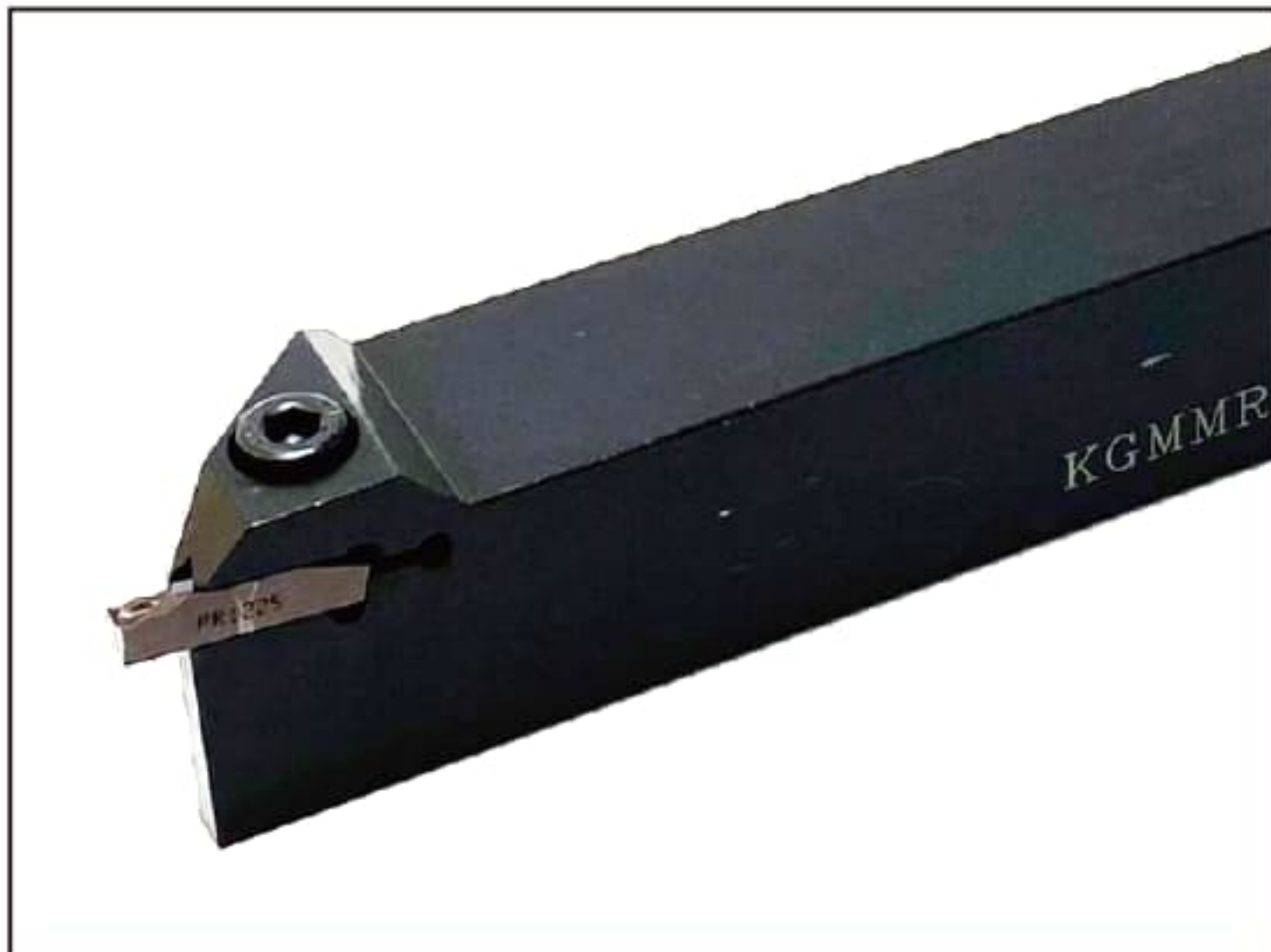

■ Right hand tool holder shown.(For Kyocera Insert)

Order number	Insert number	Dimensions (mm)						Screw	Wrench
		W		H	B	L	T		
		min	max						
KGMMR/L 2020K-3	GMM3020- GMN3	3.0	5.0	20	20	125	4.8	BX0520	LH-040
2525M-3				25	25	150			

GVFHR

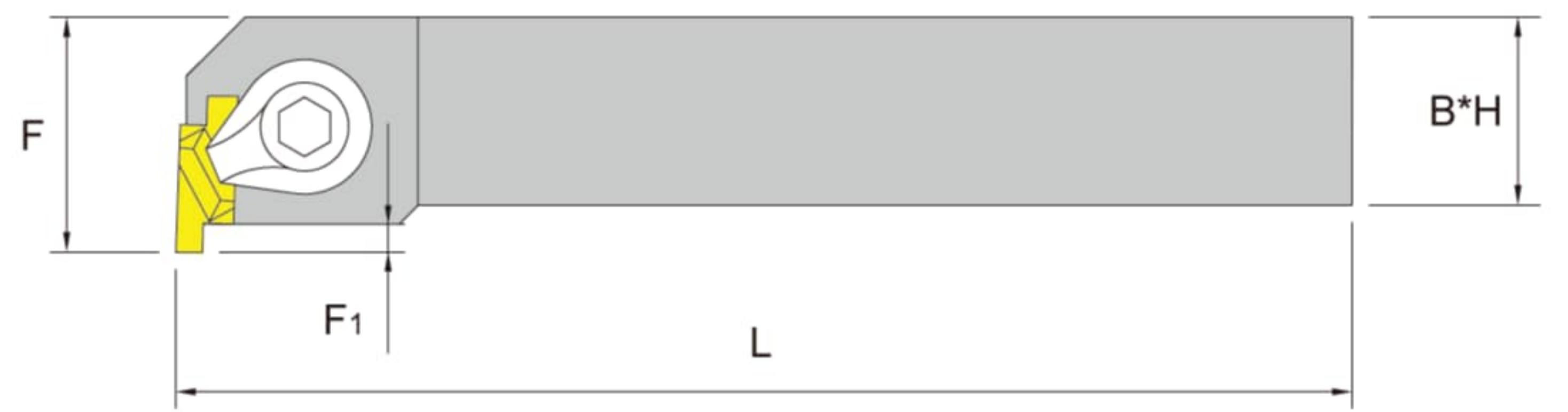
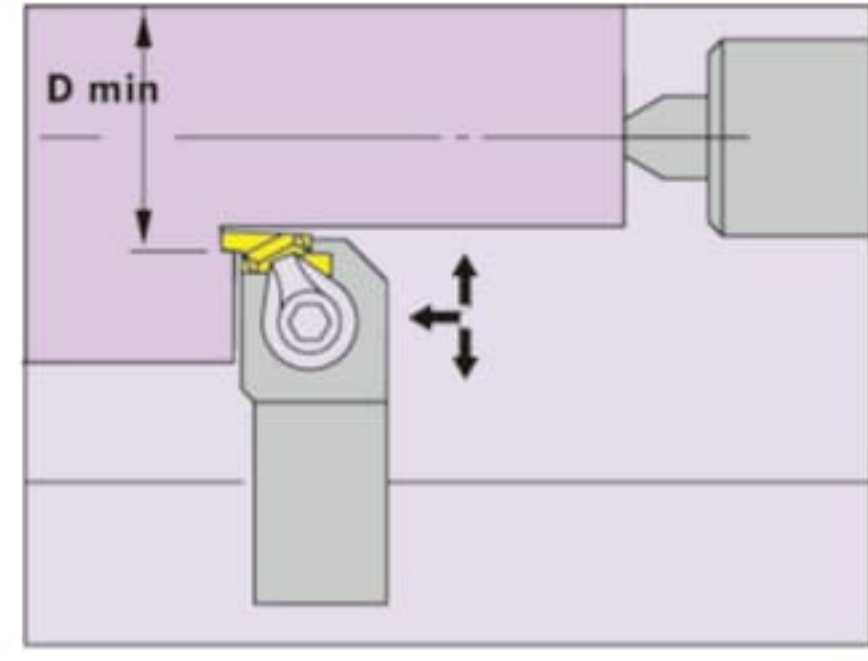

■ Right hand tool holder shown.(For Kyocera Insert)

Order number	Insert number	Dimensions (mm)								Screw	Wrench
		H	B	F	L	F ₁	D min	D max			
GVFHR 2020K-08AA	GVFL 100AA GVFL 200AA GVFL 300AA	20	20	25	125	2.2	8	∞	CPS-5V	TRX15	
2525M-08AA		25	25	32	150						

STFFR

F

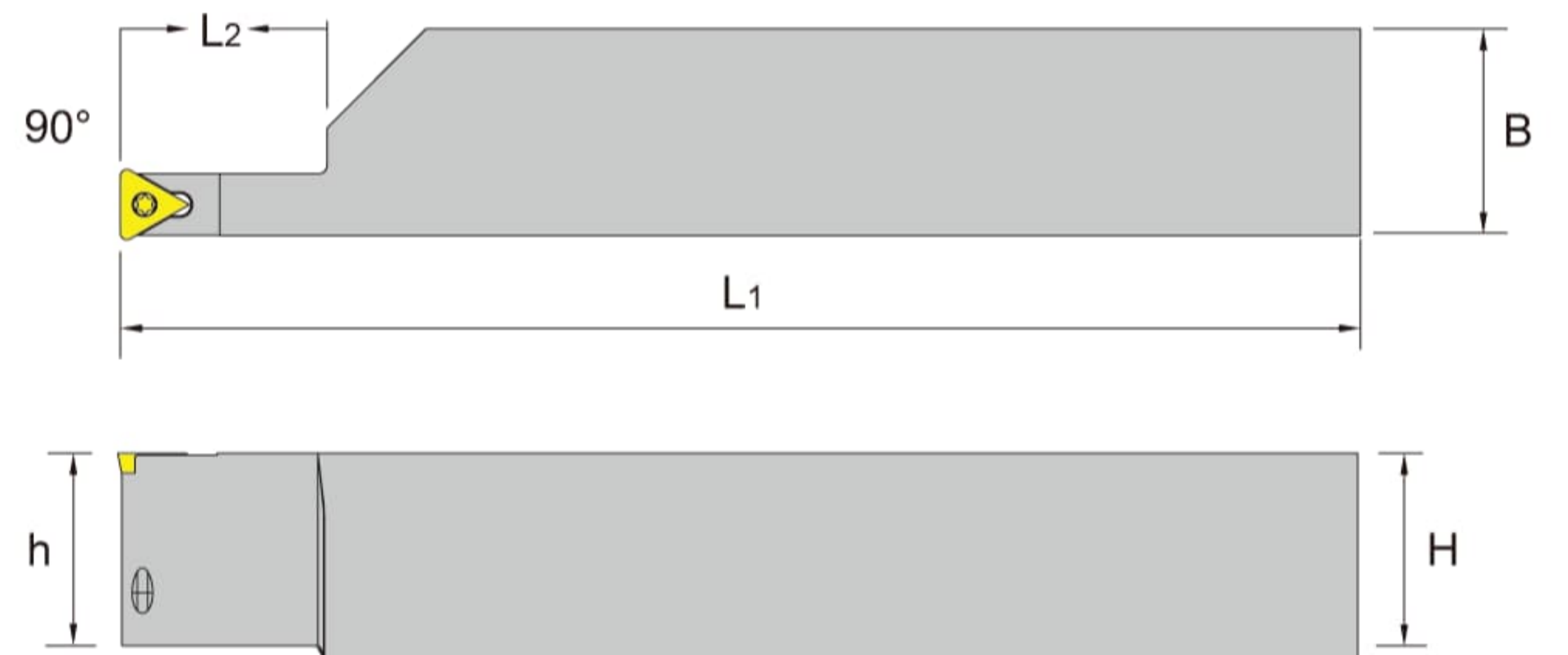
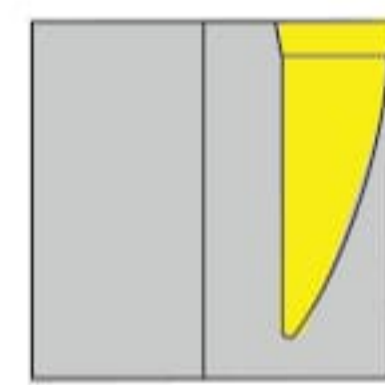
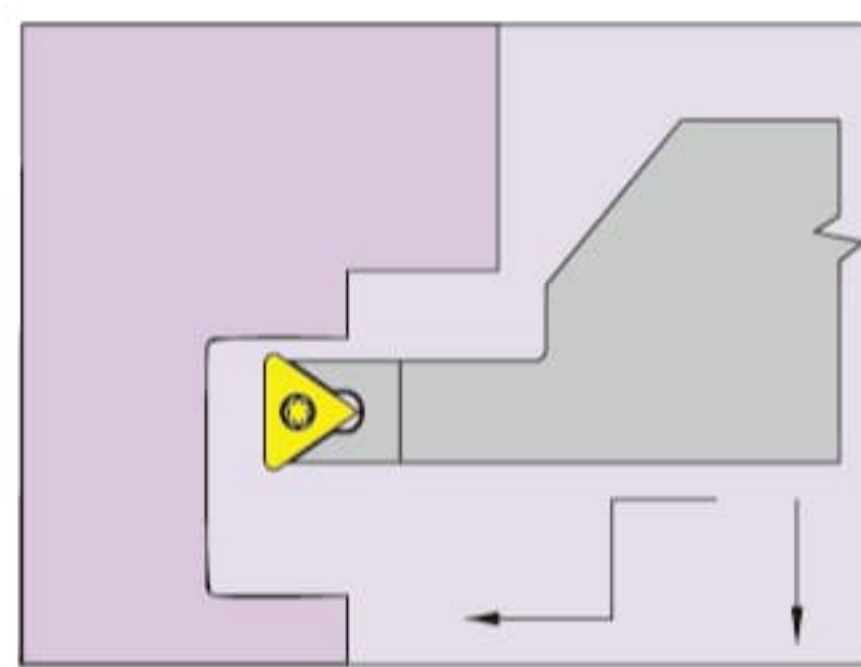

■ Right hand tool holder shown.

Order number	Insert number		Dimensions (mm)					Min cutting diameter	screw	Wrench
			H	B	L ₁	L ₂	h			
STFFR 2020K-09	TPMT	0902○○○	20	20	125	20	20	Ø80	BFTX 02506	TRX08
2525M-09			25	25	150	20	25			

GVFR

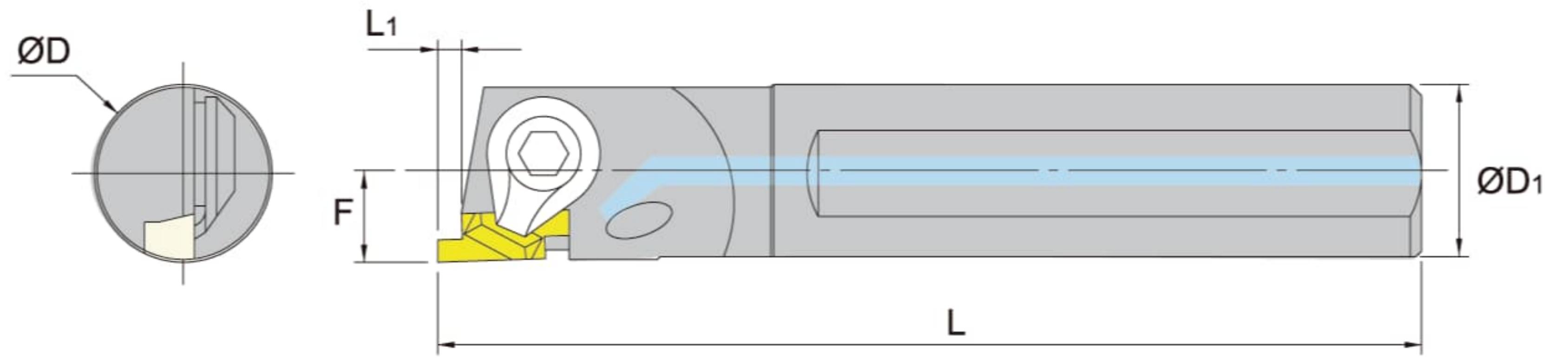
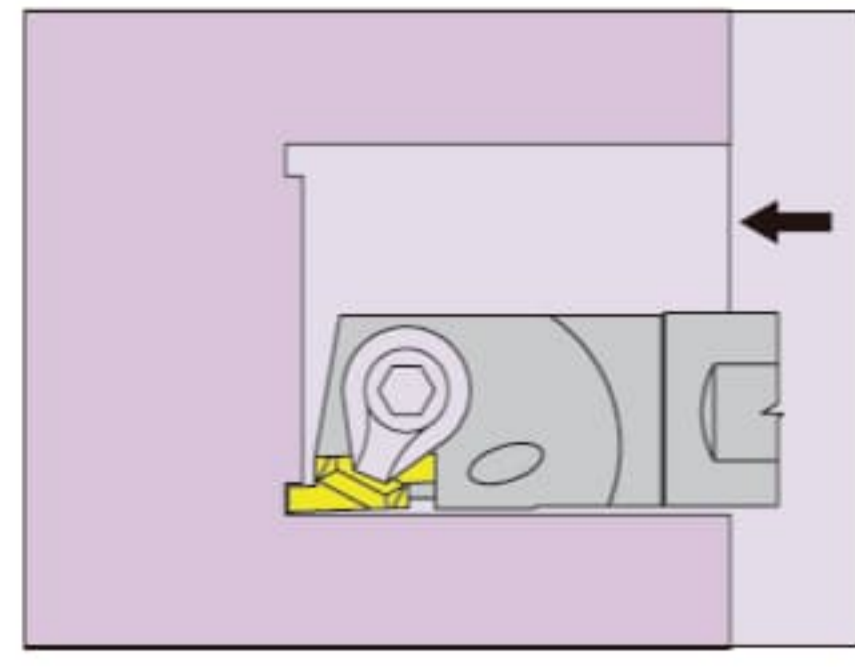
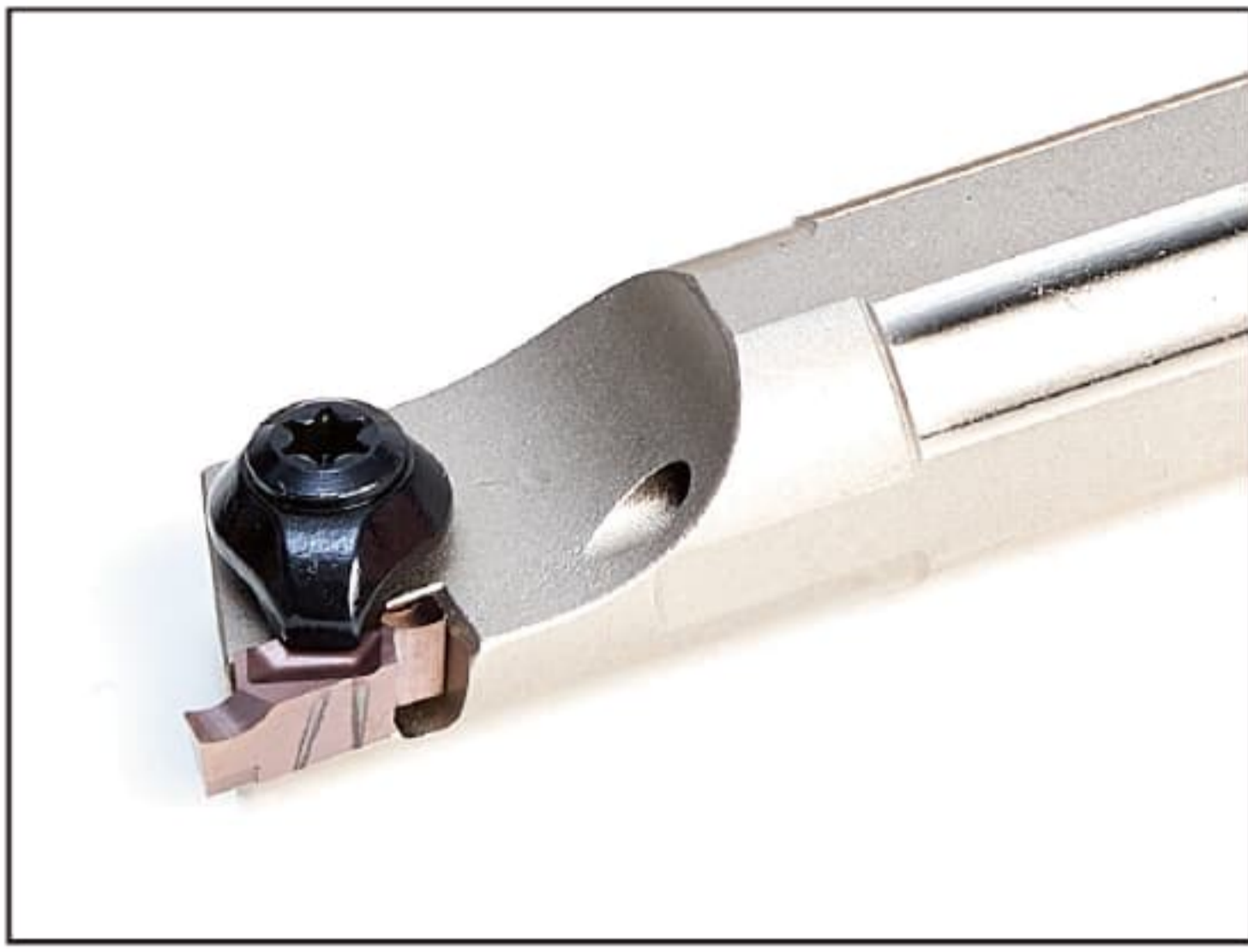

■ Right hand tool holder shown.(For Kyocera) Right hand tool for right Insert.

	Order number	Insert number	Dimensions (mm)				Clamp	Wrench	
			ØD	ØD ₁	F	L			L ₁
COOLANT	A16Q GVFR-A	GVFR 200A/340A	16	16	8	180	2.2	CPS-5F	TRX-15
	A20Q GVFR-B	GVFR 250/490B	20	20	10	180	5	CPS-5V	
	A25R GVFR-B		25	25	12.5	200	5	CPS-6V	LH-030
	A32S GVFR-B		32	32	16	250	5		
	A40T GVFR-C	GVFR 350/600C	40	40	20	300	8.1		

HFHSR

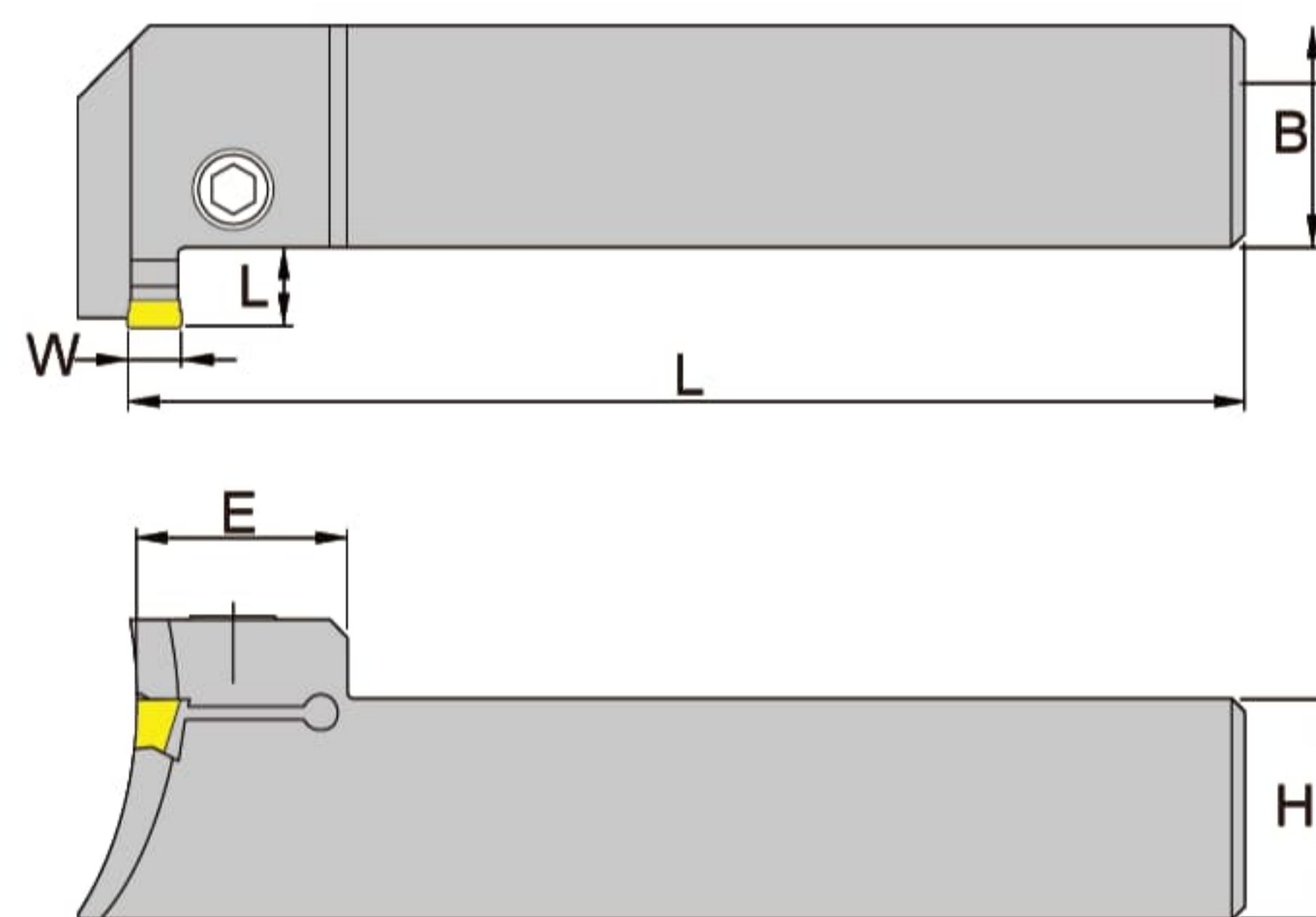

■ Right hand tool holder shown.(For Iscar Insert)

Order number	Insert number	Dimensions (mm)					screw	Wrench
		B*H	L	T	W	Dmin		
HFHSR 2525M 36-50 4T13	HFPR 4004	25	150	13	4	36	BX0620	LH-050
HFHSL 2525M 36-50 4T13	HFPR 4020			13		36		
HFHSR 2525M 70-95 5T09	HFPR 5005 HFPR 5025			09	5	70		
HFHSR 2525M 60-120 5T15				15		60		
HFHSL 2525M 60-120 5T15				15		60		