

**PCDFR**

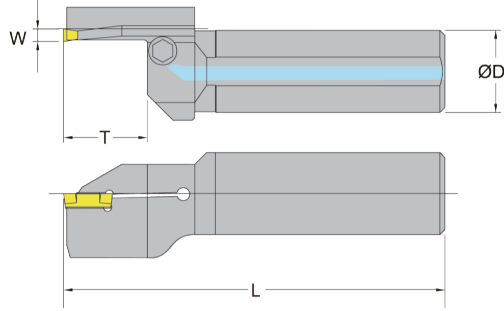
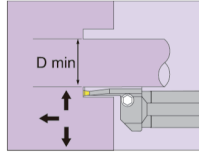
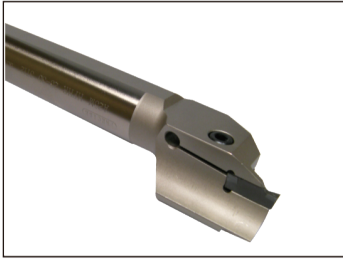

■ Right hand tool holder shown.(For Precise Insert)

	Order number	Insert number	Dimensions (mm)				Screw	Wrench	
			Ø D	L	T	W			D min
COOLANT 中心出水	A25M PCDFR 29-34 2T06	CD 200R/L/N 250R/L/N (F1/T/M1)	25	150	6	2	29	BS0620	LH-050
	PCDFR 34-44 2T06						34		
	PCDFR 44-54 2T06						44		
	PCDFR 54-70 2T12						54		
	A32M PCDFR 70-100 2T12		32	150	12	2	70		
	PCDFR 100-150 2T12						100		
	PCDFR 150-250 2T12						150		
	PCDFR 250-800 2T12						250		
COOLANT 中心出水	A25M PCDFR 29-34 3T12	CD 300R/L/N (F1/T/M1/R)	25	150	12	3	29	BS0620	LH-050
	PCDFR 34-44 3T12						34		
	PCDFR 44-54 3T12						44		
	PCDFR 54-70 3T20						54		
	A32M PCDFR 70-100 3T20		32	150	20	3	70		
	PCDFR 100-150 3T20						100		
	PCDFR 150-250 3T20						150		
	PCDFR 250-800 3T20						250		
COOLANT 中心出水	PCDFR 29-34 4T12	CD 400/N (F1/T/M1/R)	25	150	12	4	29	BS0620	LH-050
	A25M PCDFR 34-44 4T12						34		
	PCDFR 44-54 4T12						44		
	PCDFR 54-70 4T20						54		
	PCDFR 70-100 4T20		32	150	30	4	70		
	A32M PCDFR 100-150 4T20						100		
	PCDFR 150-250 4T20						150		
	PCDFR 250-800 4T20						250		